

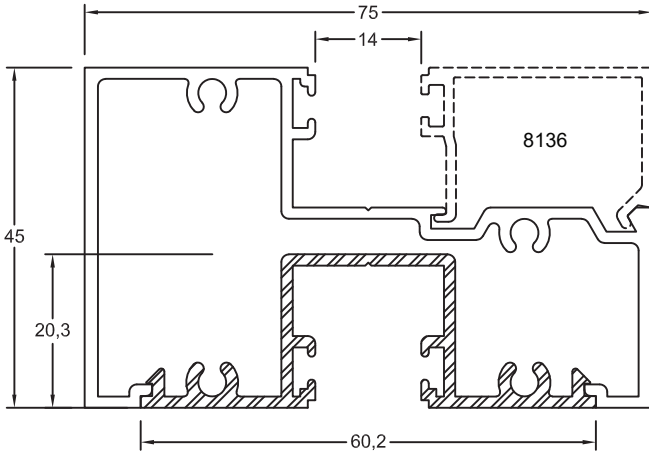

Section No.G083  
Transom  
0.927kg/m, per 422

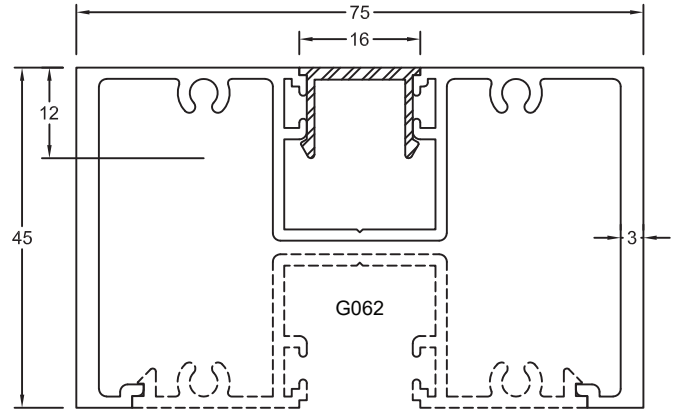

Section No.G059  
Heavy Mullion  
1.398kg/m, per 505



Section No.G062  
75/100 Glazing Infil  
0.579kg/m, per 281

Section No.G058  
Mullion  
1.057kg/m, per 511

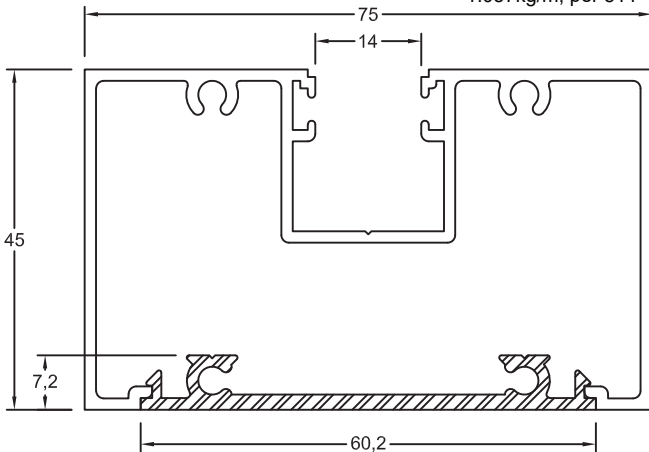

Section No.8136  
75mm Square Bead  
0.282kg/m, per 158

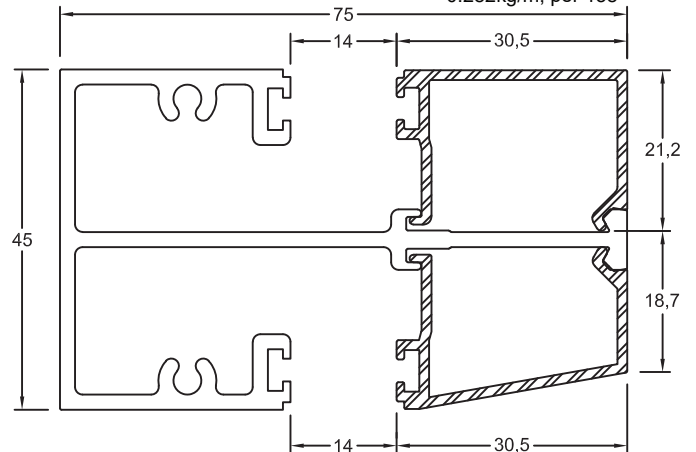

Section No.5581  
Plain Infil  
0.429kg/m, per 182

Section No.8706  
Glazing Bar  
1.286kg/m, per 463

Section No.7754  
75mm Sloping Bead  
0.267kg/m, per 150

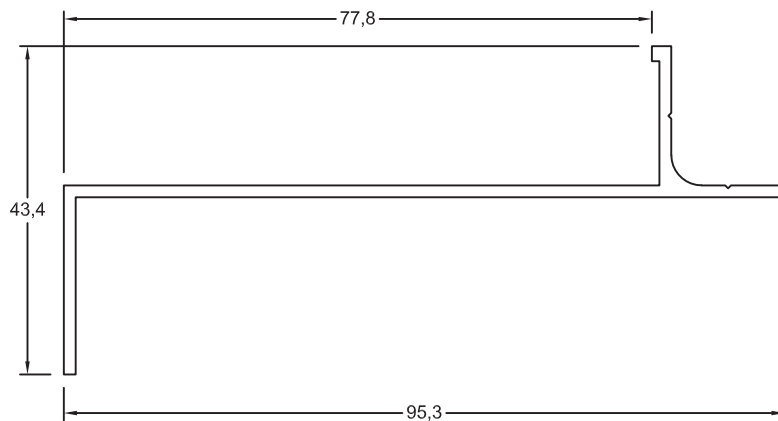

Section No.4895  
Sil Tray  
0.595kg/m, per 278



Section No.9698  
Shallow Pocket Infil  
0.429kg/m, per 182

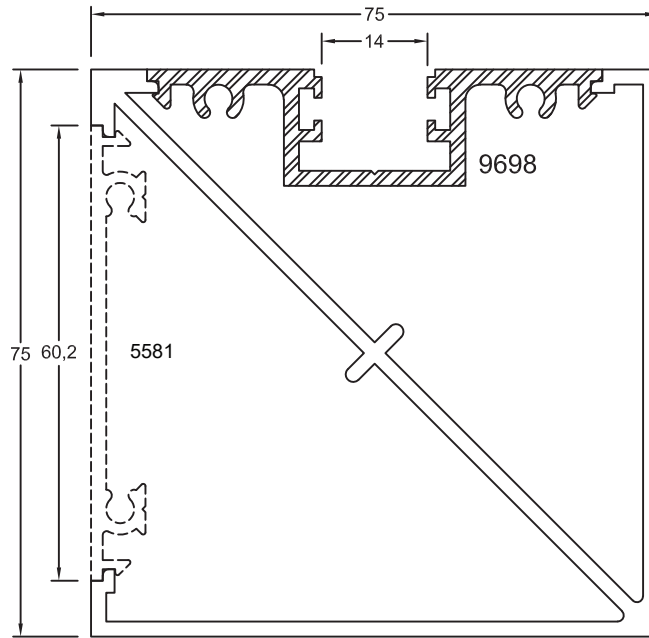

Section No.3882  
Corner Post  
1.568kg/m, per 565

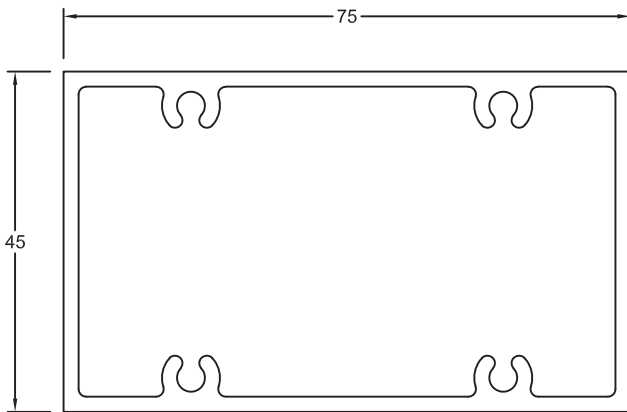

Section No.7771  
Screw Port Box  
1.532kg/m, per 240

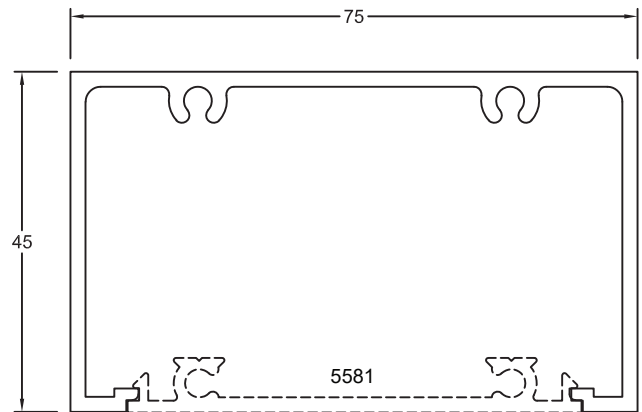

Section No.6726  
Screw Port Channel  
1.079kg/m, per 388

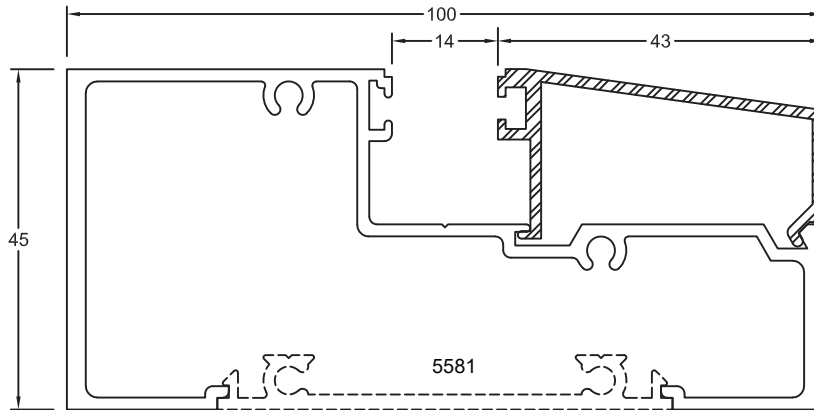

Section No.37196  
Centre Glazing Sloping Bead  
0.362kg/m, per 184

Section No.37194  
Centre Glazing Transom  
1.290kg/m, per 514

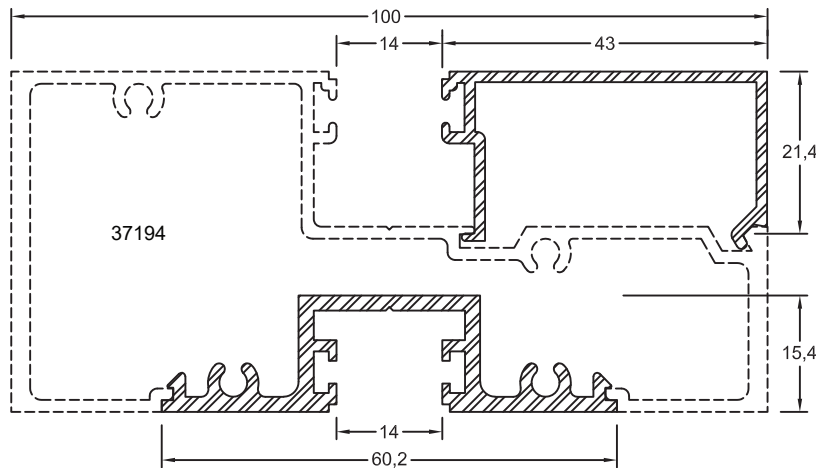

Section No.37195  
Centre Glazing Square Bead  
0.367kg/m, per 195

Section No.9698  
Shallow Pocket Infil  
0.650kg/m, per 254

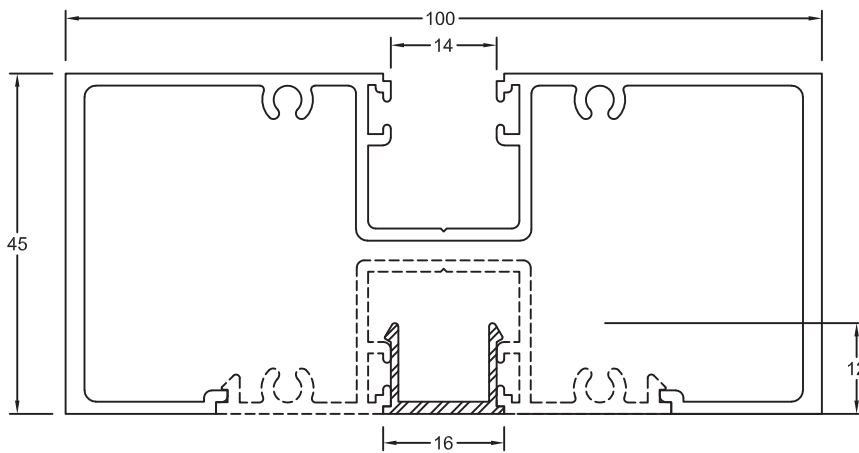

Section No.37197  
Centre Glazing Mullion  
1.522kg/m, per 600

Section No.5706  
Pocket Flush Infil  
0.126kg/m, per 77

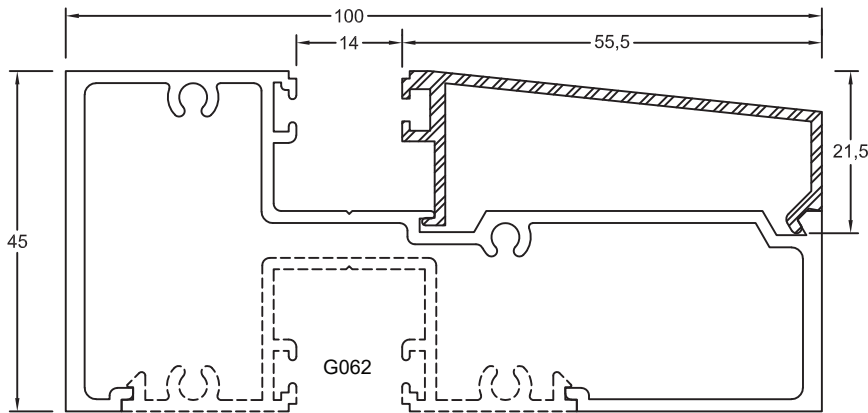

Section No.7757  
Sloping Transom Bead  
0.394kg/m, per 201

Section No.G060  
Transom  
1.295kg/m, per 514

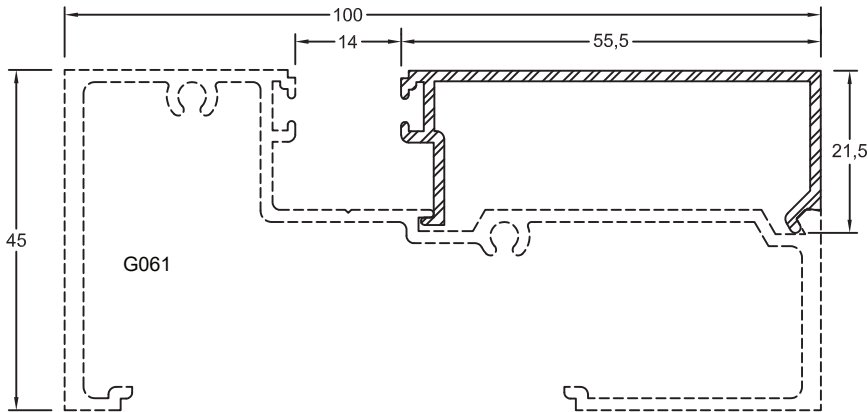

Section No.33029  
Square Transom Bead  
0.399kg/m, per 212

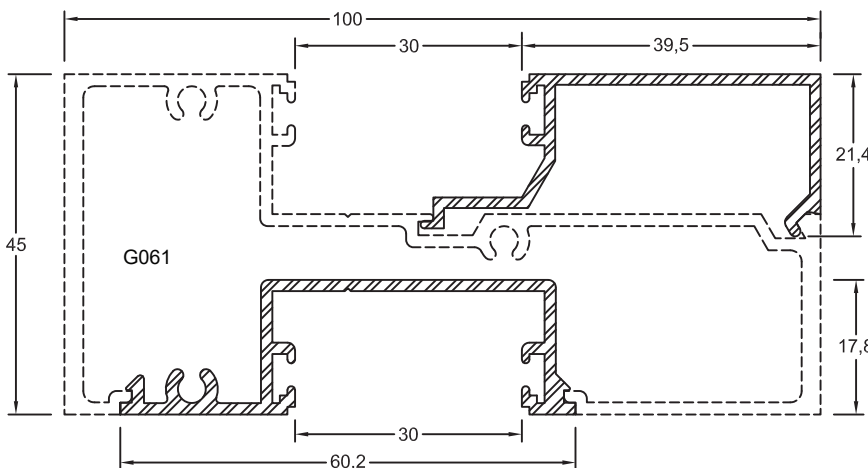

Section No.30772  
Double Glazing Bead  
0.380kg/m, per 203

Section No.30771  
Double Glazing Infil  
0.511kg/m, per 248

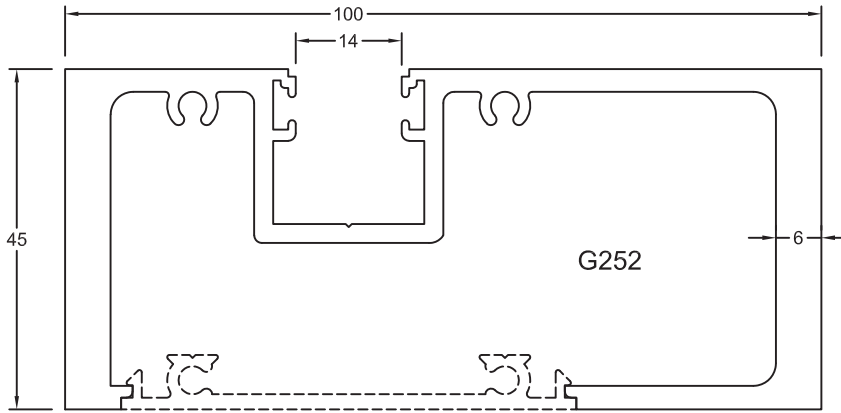

Section No.G252  
Heavy Mullion  
2.828kg/m, per 577

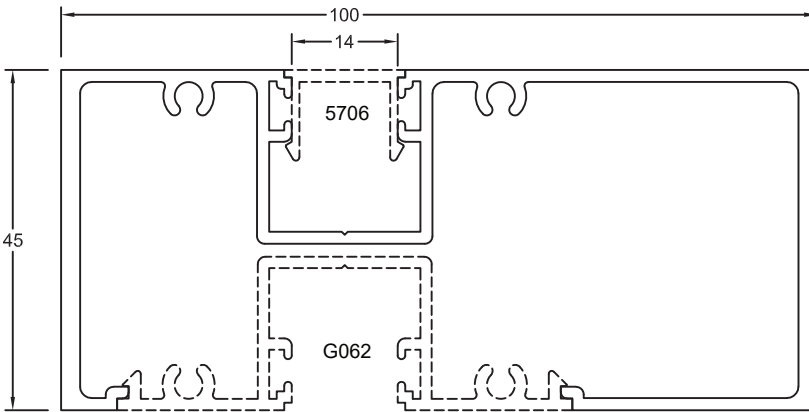

Section No.G061  
Mullion  
1.531kg/m, per 605

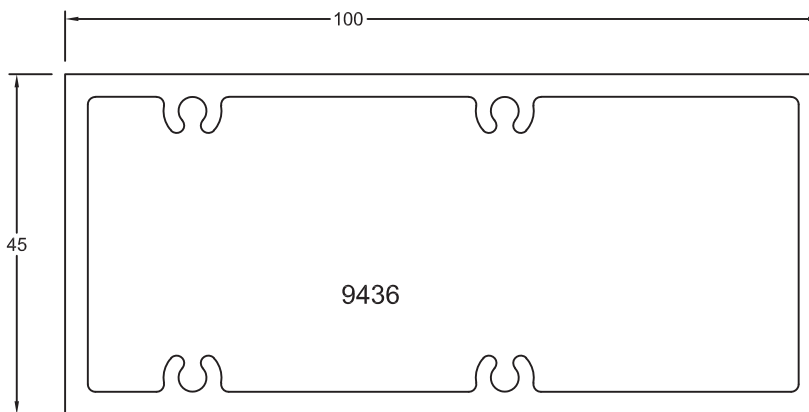

Section No.9436  
Screw Port Box  
2.478kg/m, per 290

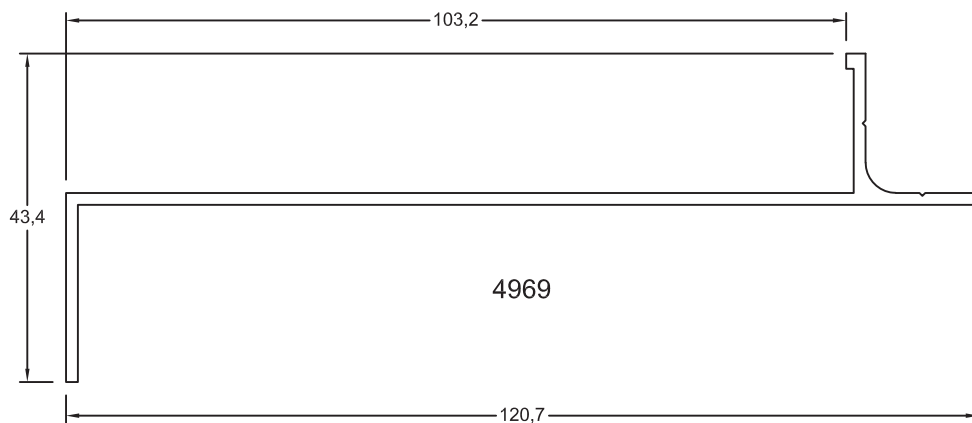
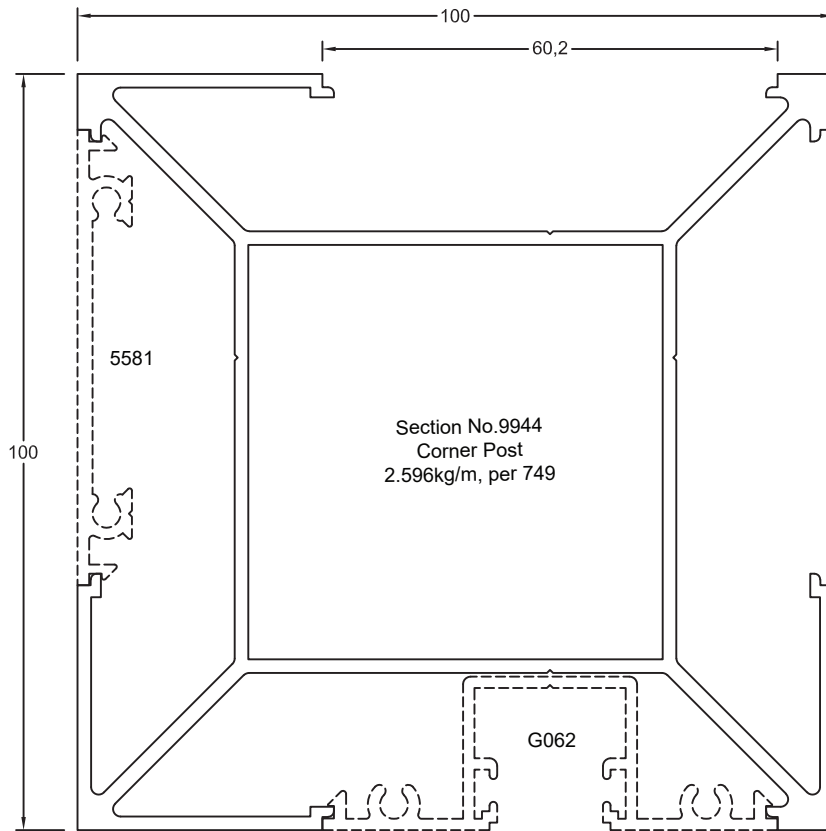

Section No.4969  
Sill Tray  
0.703kg/m, per 329