

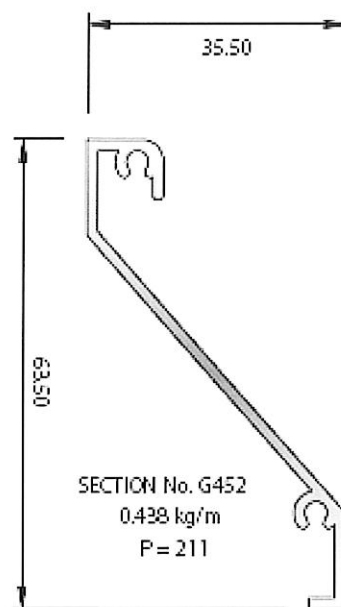

731 Great South Rd,
Penrose, Auckland NZ.
+64 09 525 3404

G452 Louver

© Copyright all rights reserved 2012



1:1

Common Framing Sections used with this section are:

2114 44.5 x 25 x 3mm CHANNEL

9677 40 x 20 x 1.6mm Unequal Angle

Sketch not to Scale

Customer	
Drawn	DM
Date	24/05/12



R & B Aluminium Ltd
 731 Great South Road Penrose
 Auckland New Zealand

RB- 440 within a 50 mm wide extrusion.

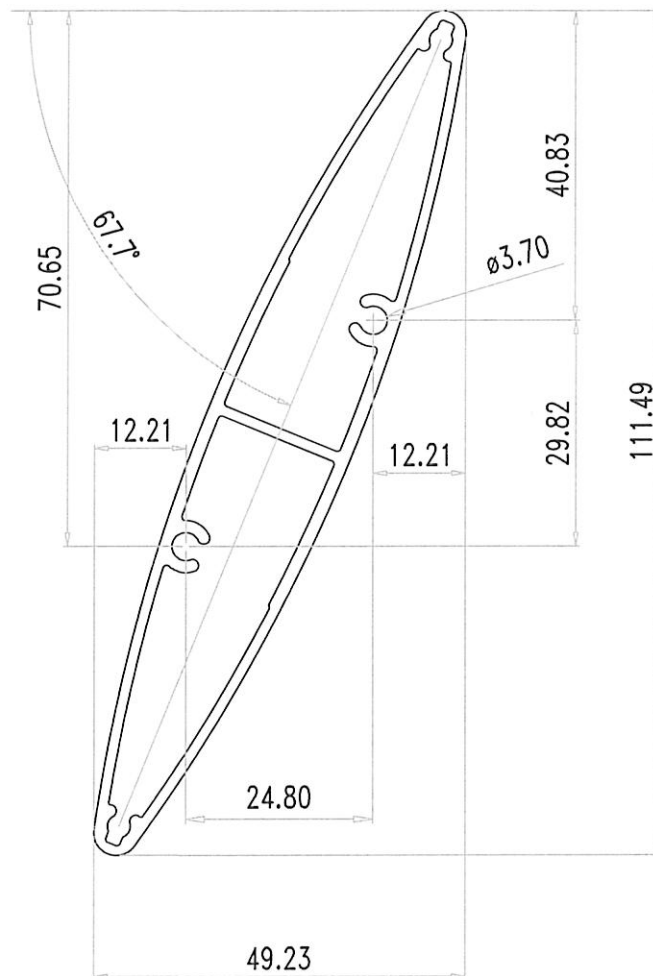

Product NO.		Est Section area	mm ²	Unspec TK.	1.60 mm	Designed		DWG NO.	RB-440
Alloy&Temper	6060-T5	Est Perimeter	mm	TK. Tolerance	+0.08 -0.12 mm	Drawn	DM	Customer	R&B
Products Grade	High	Est WT/m	kg/m	Unspec corners	r=0.30 mm	Checked		Date	30/10/14
Standard	GB5237-2008	Diameter	mm	Scale	1 : 1	Approved			